

This technical report has been previously published by the Queensland Government. The technical information in this publication is still current, however it may contain references to former departmental names. Please refer to www.qld.gov.au/dsitia for up-to-date contact details for the Department of Science, Information Technology, Innovation and the Arts.



Australian Government

Queensland
Wetlands Program



Queensland
Government

Wetland Mapping and Classification Methodology

Overall Framework

A Method to Provide Baseline Mapping and Classification for Wetlands in Queensland

VERSION 1.2

Attachment 5

**Water Body Mapping
Using the Normalised Difference Water Index (NDWI)**

Contents

1. Introduction.....	2
2. Background	2
3. Processing of NDWI in Imagine®	3
4. Composite multi-date image	4
5. Known processing problems.....	5
6. Limitations of source data	5
7. Additional “wet” image.....	5
8. References.....	6
Personal communications	6

1. Introduction

The objective of this methodology is to map water bodies to a scale of 1:100,000 across the state of Queensland in the minimum amount of time while being accurate, robust and repeatable. Using satellite remote sensing technology enables the cost effective method of covering the entire State at a constant resolution (25 metre pixel, post-1991) and across constant spectral bands. The Agency holds a significant archive of TM imagery acquired from DNR&M through its State Land and Tree Survey (SLATS) programme. Dates range from 1988 to 2003, predominantly taken in the dry season to minimise cloud cover. The dates of the images used are 1991, 1995, 1997, 1999 and 2001.

2. Background

The normalised difference water index (NDWI) is derived using similar principles to the Normalised Difference Vegetation Index (NDVI). In an NDVI (the comparison of differences of two bands, red and near-infra-red (NIR)), the presence of terrestrial vegetation and soil features is enhanced while the presence of open water features is suppressed because of the different ways in which these features reflect these wavelengths (McFeeters 1996). The NDVI index is calculated as follows:

$$\frac{(NIR - Red)}{(NIR + Red)}$$

If the equation is reversed and the green band used instead of the red, then the outcome would also be reversed, the vegetation suppressed and the open water features enhanced (McFeeters 1996). The equation for an NDWI is:

$$\frac{(Green - NIR)}{(Green + NIR)}$$

The selection of these wavelengths maximises the reflectance properties of water. That is:

- Maximise the typical reflectance of water features by using green wavelengths;
- Minimise the low reflectance of NIR by water features; and
- Maximise the high reflectance of NIR by terrestrial vegetation and soil features.

The outcomes from this equation are water features that have positive values whilst soil and terrestrial vegetation have zero or negative values (McFeeters 1996).

3. Processing of NDWI in Imagine®

Outlined below are the processing steps through ERDAS Imagine®:

Step 1 – Pre-process all images if necessary into the universal transverse mercator (UTM) projection (using the geographic datum of Australia (GDA)). In IMAGINE®, produce NDWI from each raw image. The processing steps are shown graphically on next page.

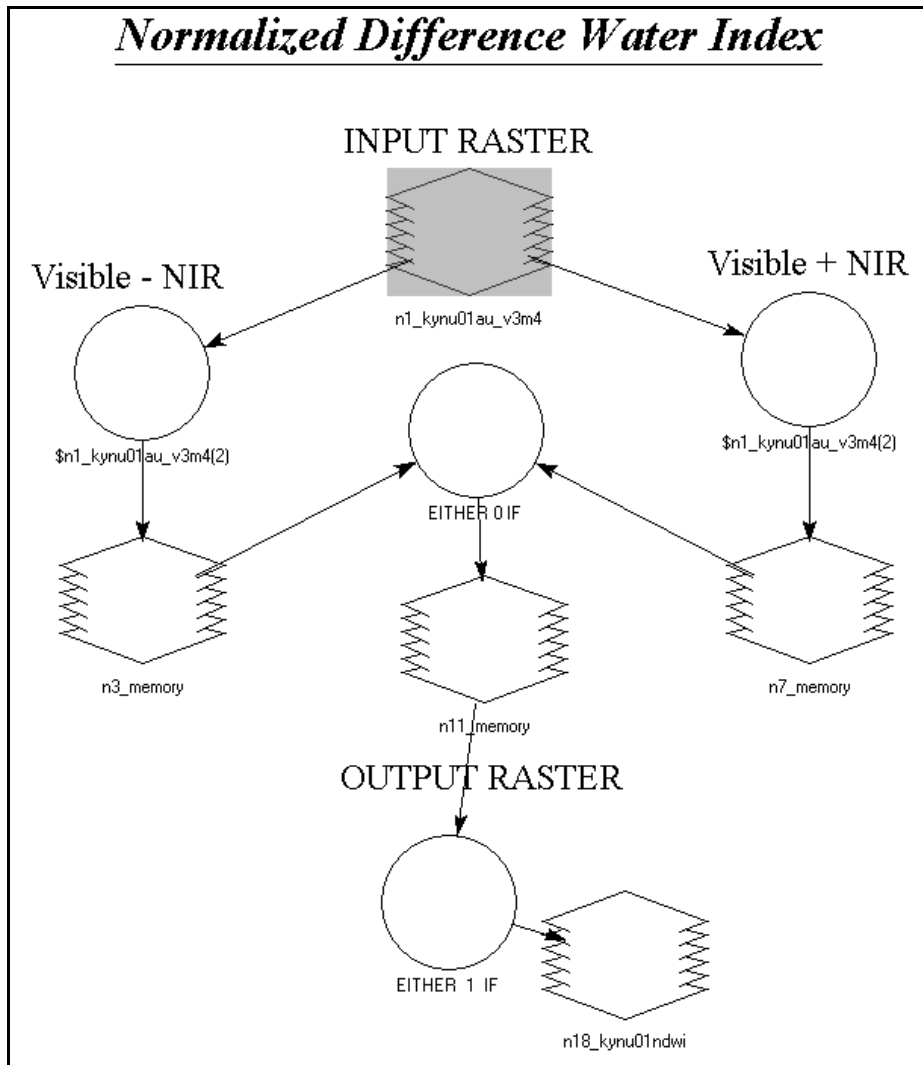

Step 2 – In IMAGINE®, convert image to ArcInfo Grid® format ensuring that data stretch is off.

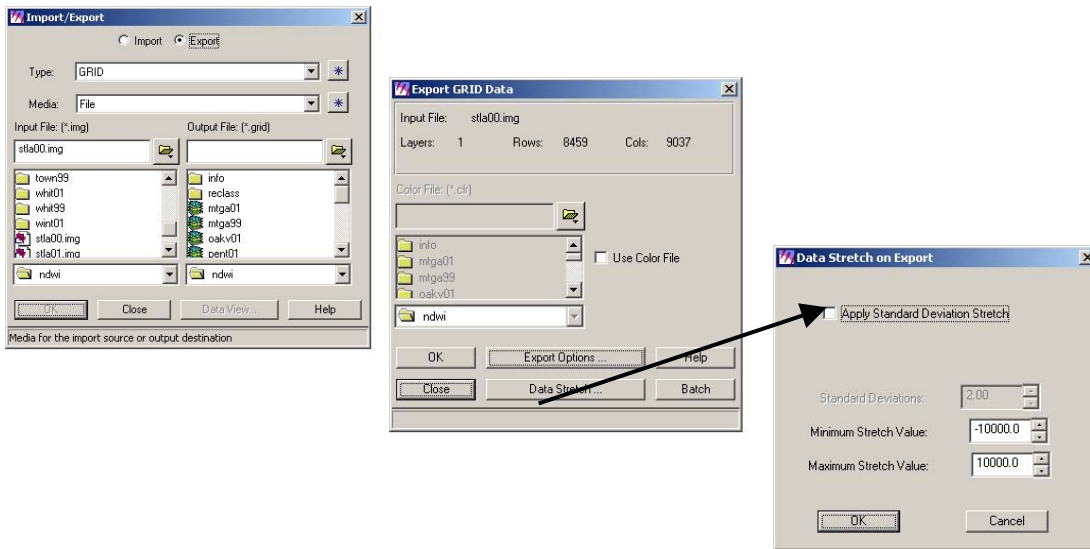

4. Composite multi-date image

After processing individual images from the NDWI, all images are summed in Spatial Analyst to give a resultant image reflecting the number of images where the water signature is present. The inundation frequency is determined by the number of images in which a water signature is present.

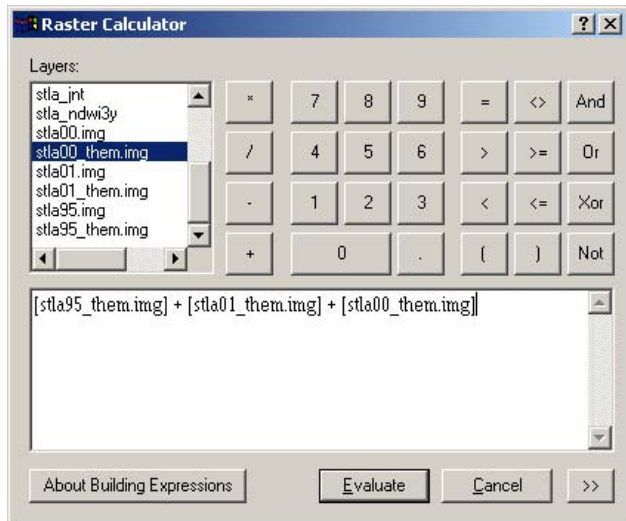

5. Known processing problems

Shadows

In almost all techniques for mapping water signatures from satellite imagery, shadow areas are a constant noise as the absorption and reflectance of wavelengths in these areas are almost identical spectrally to the absorption and reflectance of wavelengths by large open water features. This introduces an overestimation of the water body extent in area with strong relief. The lack of a suitably detailed digital elevation model (DEM) hinders attempts to filter out mountain shadow. Currently the problem is addressed using the Geoscience Australia 9" DEM and the creation of a slope mask to remove these areas.

6. Limitations of source data

There are identified shortcomings to using this archive of imagery. The images are predominantly captured during the State's dry season to minimise cloud cover. This may underestimate the true extent of many water bodies and may fail to identify many ephemeral ones. This has been negated by the use of multi-date imagery over a 15-year period but it is recognised as a shortcoming of the methodology, particularly since this period in Queensland has been dominated by drought. Other sensor technical difficulties are atmospheric haze, poor sensor calibration for some images and, significantly, shadow effects from high topographical areas, particularly along the eastern seaboard (A. Knight, pers comm).

However, its strengths lie in the high degree of geo-referenced accuracy (max RMS = 20 metres), corrected for atmospheric disturbance and its accessibility (Moffatt and Thrupp 2003). Of the seven bands available from the sensor, this methodology utilises two (bands 2 and 5), although it has been suggested that band 6 (thermal infra-red) would also be useful to this process (Moffatt and Thrupp 2003; Johnston and Barson 1993) and may be trialled in the future.

7. Additional "wet" image

To overcome this known restriction of using relatively "dry" imagery, a selection of dates has been made utilising the Bureau of Meteorology (<http://www.bom.gov.au>) and Long Paddock (<http://www.longpaddock.qld.gov.au/>) rainfall data, to find specific dates of images where there is a significant presence of water still in the drainage and wetland systems. Dates were specifically chosen to not be at the maximum rainfall times to eliminate water signatures on open floodplains. These images were acquired and rectified to the same rectification base as the archived SLATS images and processed through the NDWI procedure steps.

8. References

- Johnston R.M., and Barson M.M. (1993) Remote sensing of Australian wetlands: An evaluation of Landsat TM data for inventory and classification. *Australian Journal of Marine and Freshwater Research*. 44:235-252.
- McFeeters S.K. (1996) The use of the Normalized Difference Water Index (NDWI) in the delineation of open water features. *International Journal of Remote Sensing*. 17(7):1425-1432.
- Moffatt D.B. and Thrupp C.L. (2003) *The location and permanence of waterbodies in southwestern Queensland (Australia) – preliminary digital GIS data from Natural Heritage Trust project 972975*. Department of Natural Resources and Mines, Toowoomba.

Personal communications

Arthur Knight – Senior Biodiversity Planning Officer, Queensland Environmental Protection Agency.